

Submittal Data Sheet

Wilco SD – Suction Diffusers



Wilco SD



Project:	
Engineer:	
Contractor:	
Submitted By:	Date:
Approved By:	Date:

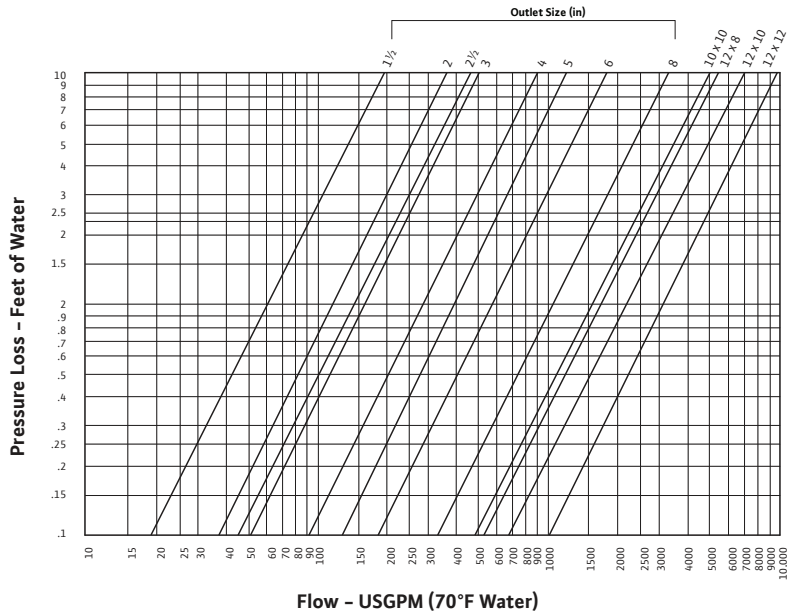

Operating Limits

Approved Fluids	
Heating Water	
Cooling and cold water	
Maximum Operating Temperature	
250°F	(120°C)
Maximum Working Pressure	
175 PSI	(12 bar)

Materials of Construction

Body	Cast Iron / Class 125
Gasket / O-Ring	Consult Factory
Cover	Cast Iron
Screen	3/16" Perforated 304 SS Screen
Start-Up Screen	20 Mesh 304 SS Start-up Screen
Bolts	Steel
Pipe Plug	Steel
Diffuser	Cast Iron

Other:

Model	Article Number	Suction x Discharge (in) 125# ANSI Flanged	Tagging Info	Quantity
WSD 2 x 1.5	2714200	2" x 1 1/2"		
WSD 2	2714201	2" x 2"		
WSD 2.5 x 2	2714202	2 1/2" x 2"		
WSD 2.5	2714203	2 1/2" x 2 1/2"		
WSD 3 x 2	2714204	3" x 2"		
WSD 3 x 2.5	2714205	3" x 2 1/2"		
WSD 3	2714206	3" x 3"		
WSD 4 x 3	2714207	4" x 3"		
WSD 4	2714208	4" x 4"		
WSD 5 x 4	2714209	5" x 4"		
WSD 5	2714210	5" x 5"		
WSD 6 x 4	2714211	6" x 4"		
WSD 6 x 5	2714212	6" x 5"		
WSD 6	2714213	6" x 6"		
WSD 8 x 6	2714214	8" x 6"		
WSD 8	2714215	8" x 8"		
WSD 10 x 8	2714216	10" x 8"		
WSD 10	2714217	10" x 10"		
WSD 12 x 8	2714218	12" x 8"		
WSD 12 x 10	2714219	12" x 10"		
WSD 12	2714220	12" x 12"		

Approval Stamp

Submittal Data Sheet

Wilco SD – Suction Diffusers



Dimensions and Weights

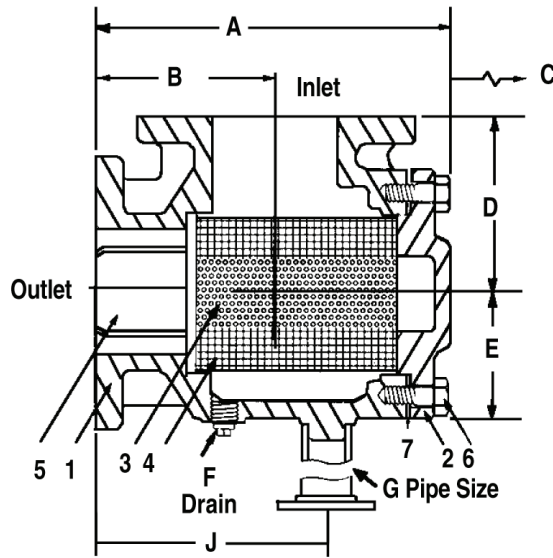

Dimensions and Weights

Dimensions - Inches (mm)

Part Number	Inlet/Outlet	Screen Dia. Openings	A	B	C	D	E	F (NPT)	G*	J	Width	Wt. lbs
2714200	2" x 1.5"	.13 (3.3)	9.38 (239)	4.50 (114)	8.13 (206)	4.50 (114)	2.19 (56)	.75	1	6.13 (156)	6.50 (165)	21 (9)
2714201	2" x 2"	.13 (3.3)	9.38 (239)	4.50 (114)	8.13 (206)	4.50 (114)	2.19 (56)	.75	1	6.13 (156)	6.50 (165)	23 (10)
2714202	2.5" x 2"	.13 (3.3)	10.38 (264)	5.00 (127)	9.38 (239)	5.00 (127)	3.13 (80)	.75	1	6.56 (167)	7.50 (191)	32 (14)
2714203	2.5" x 2.5"	.13 (3.3)	10.38 (264)	5.00 (127)	9.38 (239)	5.00 (127)	3.13 (80)	.75	1	6.56 (167)	7.50 (191)	34 (15)
2714204	3" x 2"	.13 (3.3)	8.38 (213)	4.25 (108)	5.00 (127)	4.69 (119)	3.13 (80)	.75	1	5.63 (143)	7.50 (191)	37 (17)
2714205	3" x 2.5"	.13 (3.3)	8.25 (210)	4.38 (111)	5.00 (127)	4.69 (119)	3.13 (80)	.75	1	5.75 (146)	7.50 (191)	49 (22)
2714206	3" x 3"	.13 (3.3)	9.38 (239)	4.75 (121)	5.25 (133)	4.75 (121)	3.63 (92)	.75	1	6.63 (168)	7.50 (191)	55 (25)
2714207	4" x 3"	.13 (3.3)	9.38 (239)	4.75 (121)	5.25 (133)	5.63 (143)	3.63 (92)	.75	1	6.63 (168)	9.00 (229)	57 (26)
2714208	4" x 4"	.13 (3.3)	11.13 (283)	5.75 (146)	6.34 (161)	5.75 (146)	4.25 (108)	.75	1.25	7.63 (194)	9.00 (229)	92 (42)
2714209	5" x 4"	.13 (3.3)	11.13 (283)	5.75 (146)	6.34 (161)	6.63 (168)	4.25 (108)	.75	1.25	7.63 (194)	10.00 (254)	97 (44)
2714210	5" x 5"	.13 (3.3)	12.63 (321)	6.50 (165)	7.13 (181)	6.50 (165)	4.88 (124)	1	1.25	8.63 (219)	10.00 (254)	101 (46)
2714211	6" x 4"	.13 (3.3)	11.13 (283)	5.75 (146)	6.34 (161)	7.50 (191)	4.25 (108)	.75	1.25	7.75 (197)	11.00 (279)	104 (48)
2714212	6" x 5"	.13 (3.3)	12.63 (321)	6.50 (165)	7.13 (181)	7.38 (188)	4.88 (124)	1	1.25	8.63 (219)	11.00 (279)	145 (66)
2714213	6" x 6"	.13 (3.3)	13.88 (353)	7.00 (178)	7.88 (200)	7.00 (178)	5.88 (149)	1	2	9.13 (232)	11.00 (279)	182 (83)
2714214	8" x 6"	.13 (3.3)	13.88 (353)	7.00 (178)	7.88 (200)	8.75 (222)	5.88 (149)	1	2	9.13 (232)	13.50 (343)	197 (89)
2714215	8" x 8"	.13 (3.3)	18.88 (480)	9.25 (235)	16.25 (413)	9.25 (235)	6.38 (162)	1	2	11.63 (295)	13.50 (343)	292 (132)
2714216	10" x 8"	.13 (3.3)	18.88 (480)	9.25 (235)	16.25 (413)	11.00 (279)	6.38 (162)	1	2	11.63 (295)	16.00 (406)	312 (142)
2714217	10" x 10"	.13 (3.3)	23.88 (607)	11.00 (279)	16.13 (410)	11.25 (286)	8.00 (203)	1	2	13.75 (349)	16.00 (406)	398 (181)
2714218	12" x 8"	.13 (3.3)	18.88 (480)	9.25 (235)	16.25 (413)	12.00 (305)	6.38 (162)	1	2	11.63 (295)	19.00 (483)	412 (187)
2714219	12" x 12"	.13 (3.3)	23.88 (607)	11.00 (279)	16.13 (410)	12.00 (305)	8.00 (203)	1	2	13.75 (349)	19.00 (483)	491 (223)
2714220	12" x 12"	.13 (3.3)	26.00 (660)	12.00 (305)	18.13 (461)	12.00 (305)	9.25 (235)	1	2	13.88 (353)	19.00 (483)	573 (260)

* Pipe Support supplied by contractor

WILO USA LLC

Tel: (866) 945-6872 Web: www.wilo-usa.com
 Fax: (708) 338-9455 Email: info@wilo-usa.com

WILO Canada Inc.

Tel: (866) 945-6236 Web: www.wilo-canada.com
 Fax: (403) 277-9456 Email: info@wilo-canada.com

WILO Mexico

Tel: +52 55 5586 3209 Web: www.wilo-mexico.com.mx
 Fax: +52 1 55 5413 4165 Email: roberto.valenzuela@wilo.com.mx