

Single-head pumps inline Wilco-Veroline-IPL range

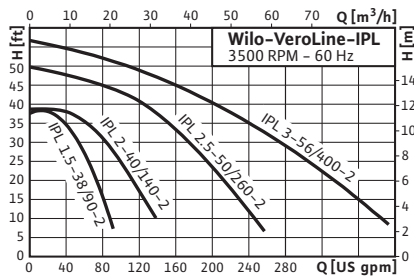

Duty chart

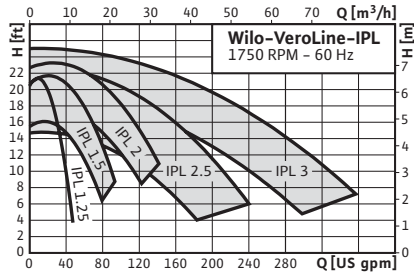

> Single-head pumps:

Single-stage low-pressure centrifugal pump with mechanical seal (Inline design).

> Application:

For pumping heating water, water/glycol-mixtures, cooling/cold water.

> Special features:

- Cataphoresis Coating standard on all models
- Suction and discharge gauge tappings ¼" NPT
- Pump legs drilled and tapped ⅜" SAE
- Industry standard flanges
 - Pump flanges ≤ 2"
 - ANSI 150 # > 2"
- Standard 56C NEMA frame Baldor motors
- 316L Stainless Steel Stub Shaft

Inline Pumps

Wilo-VeroLine-IPL

Function, Equipment & Technical data

	Wilo-VeroLine-IPL
Approved fluids (other fluids on request)	
Heating water	•
Water-glycol-mixtures at 20-40 Vol.-% glycol and fluid temperature ≤ 104 °F > 40 Vol.-% glycol > 20 Vol.-% glycol and fluid temperature > 104 °F	• • Additive dependant – please contact WILO
Cooling and cold water	•
Heat transfer oil	Custom version – please contact WILO
Application limits	
Standard version with nominal pressure, P _{max.} [PSI]	145 (10 bar)
Temperature range [°F]	15 to 250 (-10 °C to +120 °C)
Ambient temperature, max. [°F]	104 (40 °C)
Installation in closed buildings	•
Outdoor installation	Custom version – please contact WILO
Typical flange sizes	
Nominal diameters for connection	1.25", 1.5", 2", 2.5" and 3"
Flanges (acc. ASME Class 125)	< 2,5" Wilo-specific ≥ 2,5" ASME Class 125
Flanges with tapings NPT	1/4 – 18 NPT
Materials	
Pump housing and lantern	cast iron
Impeller standard version	fibre reinforced plastic (polypropylene or noryl)
Impeller special version	–
Stub shaft	stainless steel 316L
Mechanical seal	AQEGG
Other mechanical seals	on request (against extra costs)
Electrical connection (other versions on request)	
Voltages available	1~115/208-230 V, 60 Hz (≤ 2 HP) 3~208-230/460 V, 60 Hz (≥ 1 HP) 3~575 V, 60 Hz (≥ 1 HP)
Speed [RPM]	1750 – 3500
Motor/Electronics	
Integrated full motor protection	integrated protection PTC/PTO on request (on-site trip unit required)
Protection class	ODP (TEFC on request)
Insulation class	F
Motor voltages	1~115/208-230 V, 60 Hz (≤ 2 HP) 3~208-230/460 V, 60 Hz (≥ 1 HP) 3~575 V, 60 Hz (≥ 1 HP)
Installation possibilities	
Pipe installation (up to 20 hp motor power)	•
Support bracket installation	•

• = available, – = not available

Pump Curves

Wilo-VeroLine-IPL 1.25-21/50-4

Speed 1750 RPM

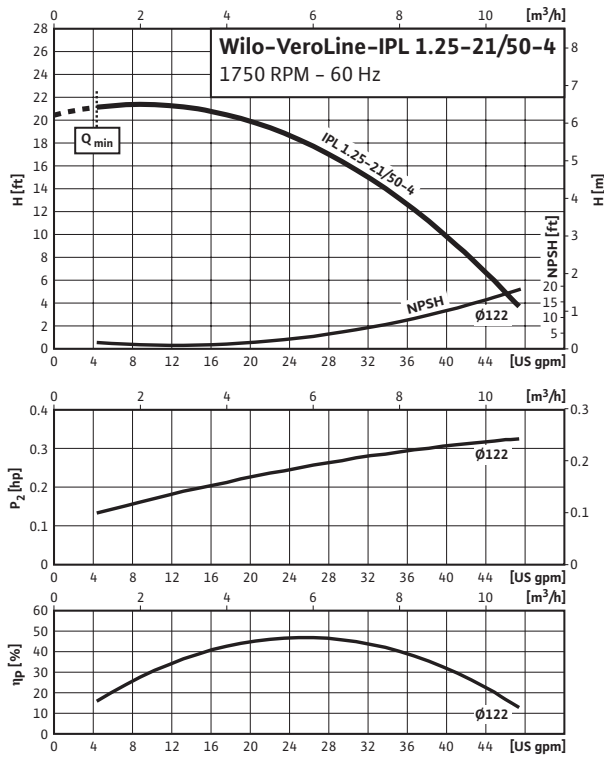

Wilo-VeroLine-IPL 1.5-22/95-4 to 1.5-16/80-4

Speed 1750 RPM

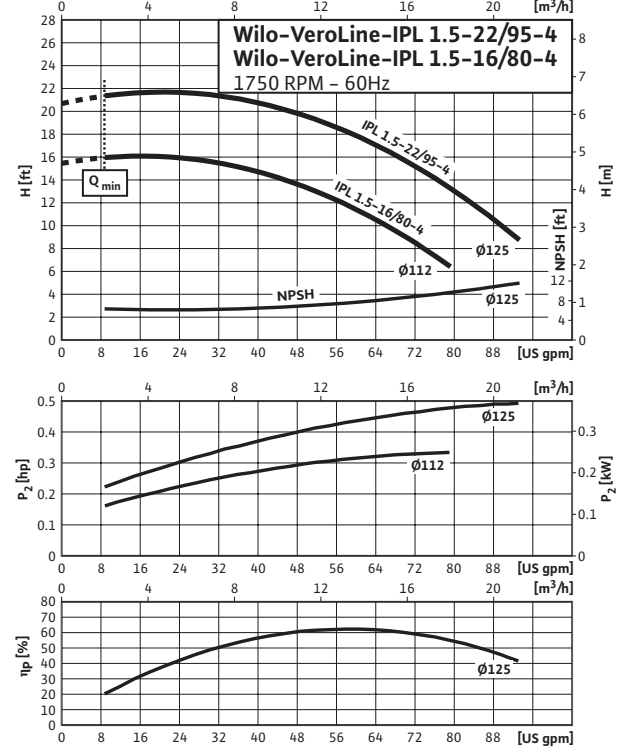

Wilo-VeroLine-IPL 2-23/140-4 to 2-18/125-4

Speed 1750 RPM

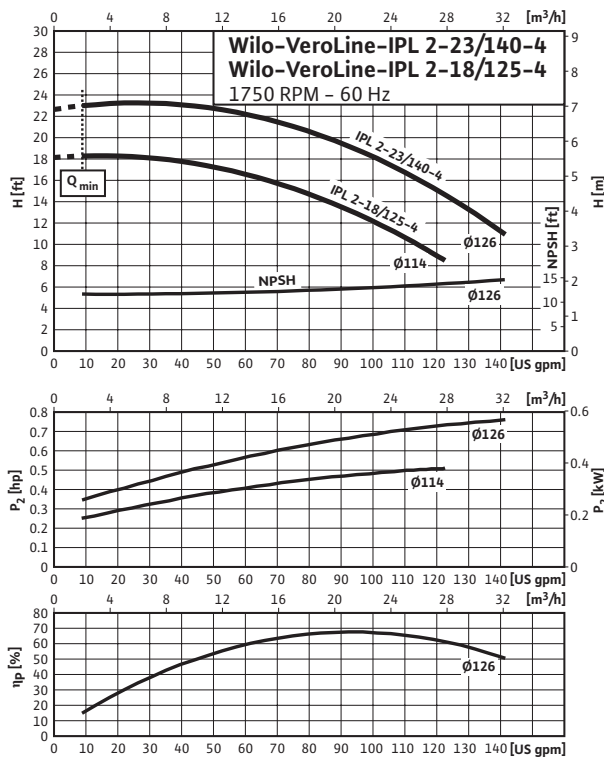

Wilo-VeroLine-IPL 2.5-23/240-4 to 2.5-15/185-4

Speed 1750 RPM

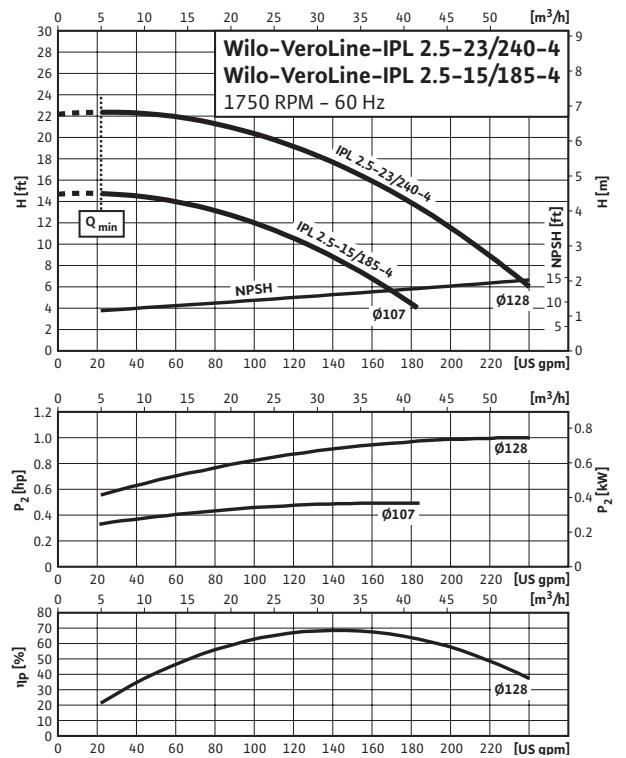

Inline Pumps

Wilo-VeroLine-IPL

Pump Curves

Wilo-VeroLine-IPL 3-26/360-4 to 3-20/300-4

Speed 1750 RPM

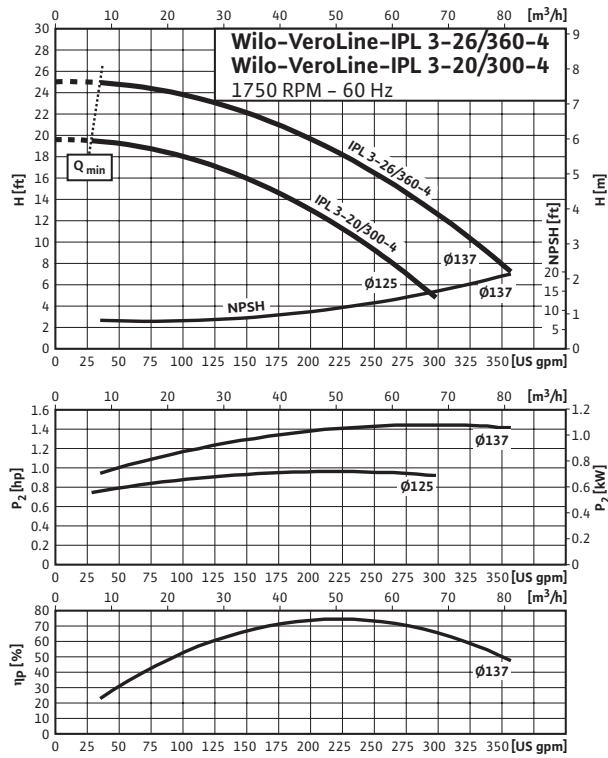

Pump Curves

Wilo-VeroLine-IPL 1.5-38/90-2

Speed 3500 RPM

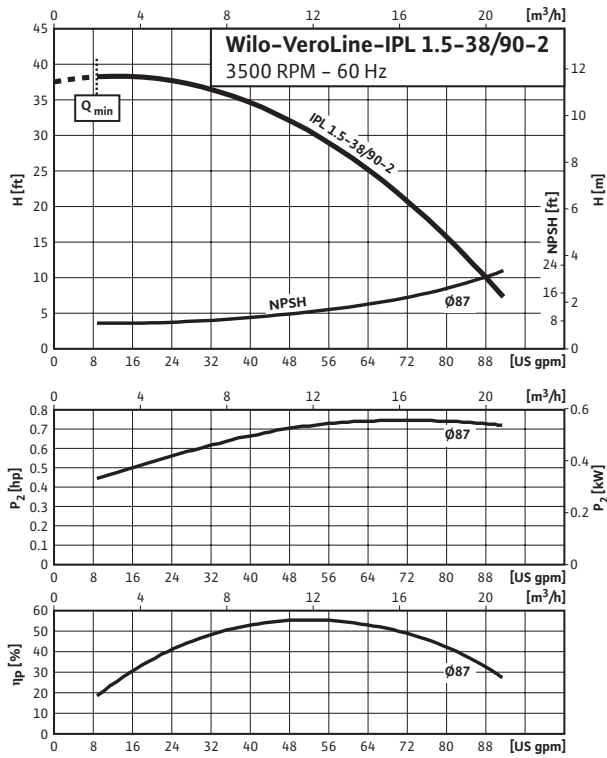

Wilo-VeroLine-IPL 2-40/140-2

Speed 3500 RPM

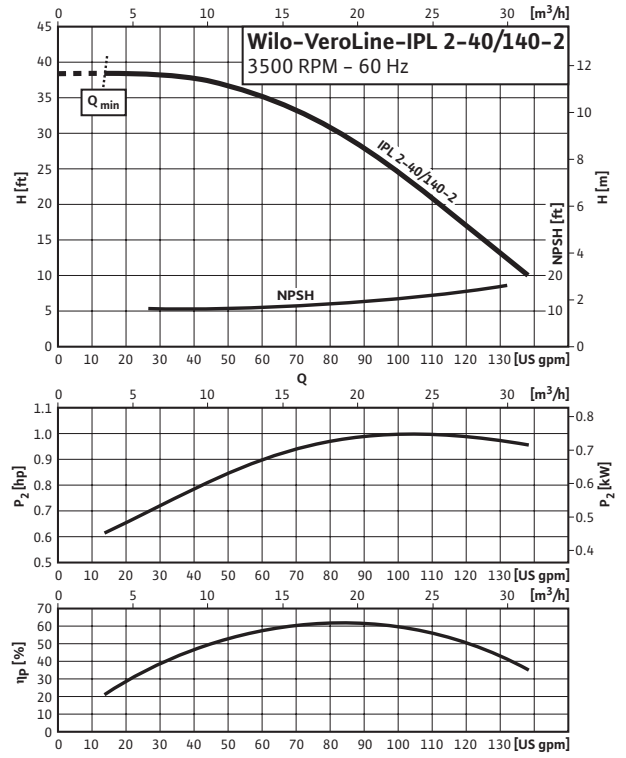

Wilo-VeroLine-IPL 2.5-50/260-2

Speed 3500 RPM

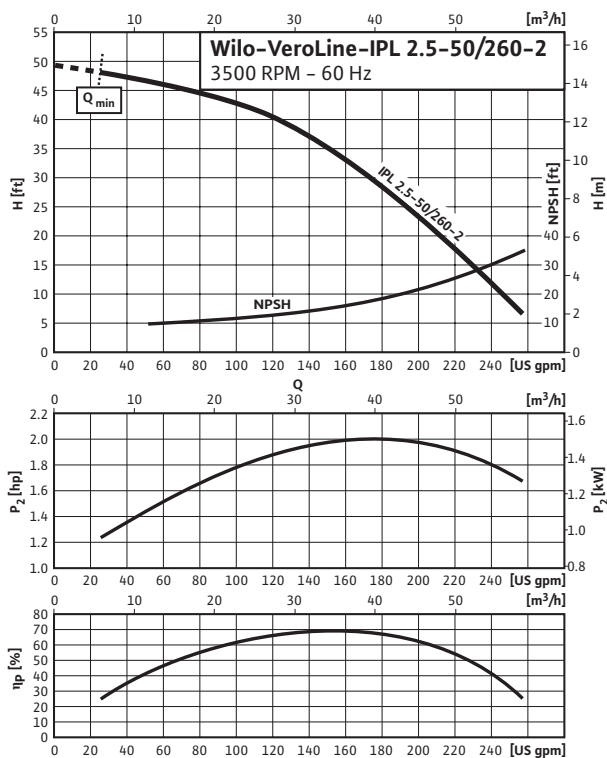

Wilo-VeroLine-IPL 3-56/400-2

Speed 3500 RPM

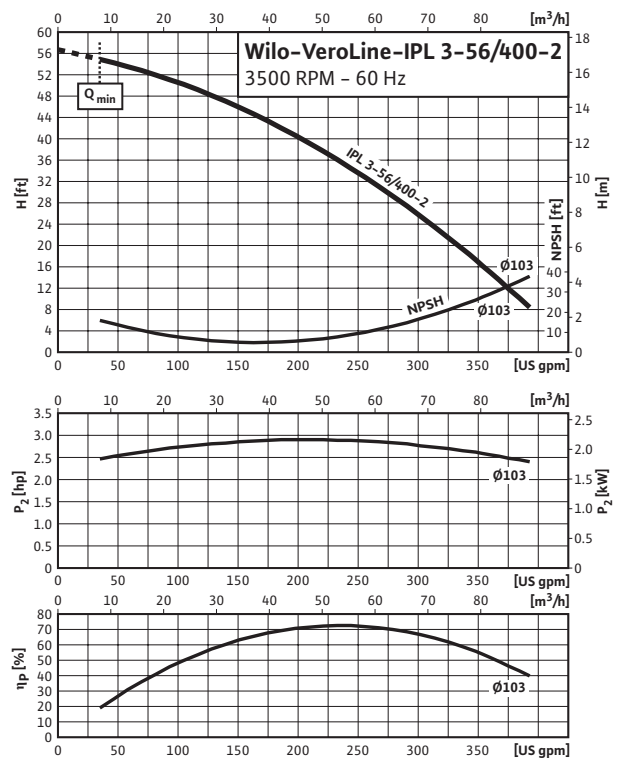

Inline Pumps

Wilo-VeroLine-IPL

Wiring diagrams, Motor Data

Wiring diagrams

Wiring diagrams are specific to and included with each motor.
Check rotation on start-up on both single and three phase motors.

Motor data

nominal Speed [RPM]	Motor Power [HP]	Voltage [V]	Phase [-]	Full Load Current [A]
1750	0.33	115/208-230	1	6 / 3.2 - 3
1750	0.5	115/208-230	1	8.4 / 4.4 - 4.2
1750	0.75	115/208-230	1	10.2 / 5.4 - 5.1
1750	1	115/208-230	1	13.4 / 7.4 - 6.7
1750	1	208-230/460	3	3.4 / 1.7
1750	1	575	3	1.4
1750	1.5	115/208-230	1	18 / 9.5 - 9
1750	1.5	208-230/460	3	5 - 4.8 / 2.4
1750	1.5	575	3	1.9
3500	0.75	115/208-230	1	9.4 / 4.9 - 4.7
3500	1	115/208-230	1	15 / 7.9 - 7.5
3500	1	208-230/460	3	3.7-3.6 / 1.8
3500	1	575	3	1.2
3500	2	115/208-230	1	24 / 12.6 - 12
3500	2	208-230/460	3	6.2 - 5.8 / 2.9
3500	2	575	3	2.3
3500	3	208-230/460	3	8.5 - 8 / 4
3500	3	575	3	3

Dimensions, weights

Dimension drawing

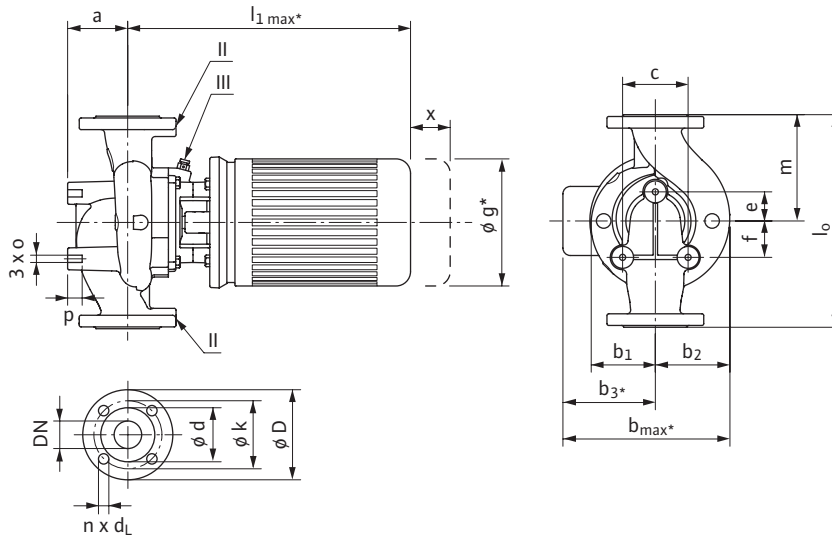

II gauge tappings ¼-18 NPT

III vent plug ⅜

* dimension dependant on motor manufacturer

Dimensions, weights – US units

Pump Type	DN	a	b ₁	b ₂	b ₃ *	b _{max}	c	e	f	g*	l ₀	l _{1 max} *	m	o	p	x	Weight
	[inch]	[inch]	[inch]	[inch]	[inch]	[inch]	[inch]	[inch]	[inch]	[inch]	[inch]	[inch]	[inch]	[inch]	[inch]	[inch]	[Lbs]
IPL1.25-21/50-4	1¼"	2¾	3¾	4 ¹ / ₁₆	5¼	9 ¹ / ₁₆	3 ⁹ / ₁₆	1 ⁹ / ₁₆	1 ¹⁵ / ₁₆	7	11	17 ¹¹ / ₁₆	5½	¾	1 ³ / ₁₆	5 ⁷ / ₈	52.0
IPL1.5-16/80-4	1½"	2 ¹⁵ / ₁₆	4 ⁵ / ₁₆	4¾	5¼	9 ⁹ / ₁₆	3 ⁹ / ₁₆	1 ⁹ / ₁₆	1 ¹⁵ / ₁₆	7	13	17 ⁷ / ₁₆	6½	¾	1 ³ / ₁₆	5 ⁷ / ₈	56.7
IPL1.5-22/95-4	1½"	2 ¹⁵ / ₁₆	4 ⁵ / ₁₆	4¾	5¼	9 ⁹ / ₁₆	3 ⁹ / ₁₆	1 ⁹ / ₁₆	1 ¹⁵ / ₁₆	7	13	17 ⁷ / ₁₆	6½	¾	1 ³ / ₁₆	5 ⁷ / ₈	58.6
IPL2-18/125-4	2"	3½	4½	5 ¹ / ₈	5¼	9¾	4 ¹ / ₈	1 ⁹ / ₁₆	1 ¹⁵ / ₁₆	7	14	17 ⁹ / ₁₆	6¾	¾	1 ³ / ₁₆	5 ⁷ / ₈	66.4
IPL2-23/140-4	2"	3½	4½	5 ¹ / ₈	5¼	9¾	4 ¹ / ₈	1 ⁹ / ₁₆	1 ¹⁵ / ₁₆	7	14	17 ⁹ / ₁₆	6¾	¾	1 ³ / ₁₆	5 ⁷ / ₈	76.3
IPL2.5-15/185-4	2½"	3¾	4 ¹¹ / ₁₆	5 ⁷ / ₁₆	5¼	10 ¹ / ₈	5 ⁵ / ₁₆	1 ⁹ / ₁₆	2 ³ / ₁₆	7	13½	17 ¹³ / ₁₆	6¾	¾	1 ³ / ₁₆	5 ⁷ / ₈	78.7
IPL2.5-23/240-4	2½"	3¾	4 ¹¹ / ₁₆	5 ⁷ / ₁₆	5¼	10 ¹ / ₈	5 ⁵ / ₁₆	1 ⁹ / ₁₆	2 ³ / ₁₆	7	13½	17 ¹³ / ₁₆	6¾	¾	1 ³ / ₁₆	5 ⁷ / ₈	96.8
IPL3-20/300-4	3"	4 ¹ / ₈	4 ¹⁵ / ₁₆	6	5¾	10 ⁷ / ₈	5 ⁵ / ₁₆	1 ⁹ / ₁₆	2 ³ / ₁₆	7	15	18 ¹ / ₁₆	7	¾	1 ³ / ₁₆	5 ⁷ / ₈	103.6
IPL3-26/360-4	3"	4 ¹ / ₈	4 ¹⁵ / ₁₆	6	5¾	10 ¹¹ / ₁₆	5 ⁵ / ₁₆	1 ⁹ / ₁₆	2 ³ / ₁₆	7	15	18 ¹ / ₁₆	7	¾	1 ³ / ₁₆	5 ⁷ / ₈	110.7
IPL1.5-38/90-2	1½"	2 ¹⁵ / ₁₆	3 ¹ / ₈	3 ⁹ / ₁₆	5¼	8 ³ / ₈	3 ⁹ / ₁₆	1 ⁹ / ₁₆	1 ¹⁵ / ₁₆	7	10	17 ¹¹ / ₁₆	5	¾	1 ³ / ₁₆	5 ⁷ / ₈	56.2
IPL2-40/140-2	2"	3¼	3½	4 ¹ / ₁₆	5¼	8¾	3 ⁹ / ₁₆	1 ⁹ / ₁₆	1 ¹⁵ / ₁₆	7	11½	17 ⁷ / ₈	5¾	¾	1 ³ / ₁₆	5 ⁷ / ₈	65.7
IPL2.5-50/260-2	2½"	3 ⁵ / ₈	3 ⁷ / ₈	4 ¹¹ / ₁₆	5¾	9 ⁵ / ₈	4 ¹ / ₈	1 ⁹ / ₁₆	1 ¹⁵ / ₁₆	7	13½	18	6¾	¾	1	5 ⁷ / ₈	91.2
IPL3-56/400-2	3"	3 ¹⁵ / ₁₆	4¼	5 ⁵ / ₁₆	5¾	10	5 ⁵ / ₁₆	1 ⁹ / ₁₆	2 ³ / ₁₆	7	14	18 ¹ / ₈	7	¾	1	5 ⁷ / ₈	97.9

Inline Pumps

Wilo-VeroLine-IPL

Dimensions, weights

Dimensions, weights – metric units

Pump Type	DN	a	b ₁	b ₂	b ₃ *	b _{max}	c	e	f	g*	l ₀	l _{1 max} *	m	o	p	x	Weight
	[mm]	[mm]	[mm]	[mm]	[mm]	[mm]	[mm]	[mm]	[mm]	[mm]	[mm]	[mm]	[mm]	[inch]	[mm]	[mm]	[kg]
IPL1.25-21/50-4	32	70.2	96.0	103.5	133.4	229.4	90	40	50	177.8	279.4	448.8	139.7	3/8	20	53.7	23.6
IPL1.5-16/80-4	40	75.0	109.0	121.0	133.4	242.4	90	40	50	177.8	330.2	443.6	165.1	3/8	20	48.5	25.7
IPL1.5-22/95-4	40	75.0	109.0	121.0	133.4	242.4	90	40	50	177.8	330.2	443.6	165.1	3/8	20	48.5	26.6
IPL2-18/125-4	50	88.9	114.4	129.7	133.4	247.8	104	40	50	177.8	355.6	446.1	171.5	3/8	20	51.0	30.1
IPL2-23/140-4	50	88.9	114.4	129.7	133.4	247.8	104	40	50	177.8	355.6	446.1	171.5	3/8	20	51.0	34.6
IPL2.5-15/185-4	65	95.3	118.5	138.3	133.4	256.8	135	40	55	177.8	342.9	452.1	171.4	3/8	20	57.0	35.7
IPL2.5-23/240-4	65	95.3	118.5	138.3	146.1	256.8	135	40	55	177.8	342.9	452.1	171.4	3/8	20	57.0	43.9
IPL3-20/300-4	80	105	125.0	152.0	146.1	277.0	135	40	55	177.8	381.0	458.1	177.8	3/8	20	63.0	47.0
IPL3-26/360-4	80	105	125.0	152.0	146.1	271.1	135	40	55	177.8	381.0	458.1	177.8	3/8	20	63.0	50.2
IPL1.5-38/90-2	40	75.0	79.0	90.0	133.4	212.4	90	40	50	177.8	254.0	448.6	127.0	3/8	20	50.8	25.5
IPL2-40/140-2	50	82.5	88.3	102.5	133.4	221.7	90	40	50	177.8	292.1	453.8	146.1	3/8	20	56.0	29.8
IPL2.5-50/260-2	65	92.5	99.0	119.0	146.1	245.1	104	40	50	177.8	342.9	457.9	171.4	3/8	25	67.3	41.4
IPL3-56/400-2	80	100	108.0	135.0	146.1	254.1	135	40	55	177.8	355.6	459.9	177.8	3/8	25	69.3	44.4

Flange Dimensions

DN		Ø D		Ø d ₁		Ø k		n x d _L	
		[in]	[mm]	[in]	[mm]	[in]	[mm]	[units x in]	[units x mm]
1¼"	32	4¾	121	27/8	73	3½	89	2 x 9/16	2 x 14
1½"	40	4¾	121	27/8	73	3½	89	2 x 9/16	2 x 14
2"	50	5¼	133	37/16	87	4	102	4 x 9/16	4 x 14
2½"	65	7	177,8	45/8	117,6	5½	139,7	4 x ¾	4 x 19
3"	80	7½	190,5	51/8	130,4	6	152,4	4 x ¾	4 x 19